



World Class Performance

The New Global Standard
for Abrasive, Scaling, and
Corrosive Slurries, Sludge,
Liquids and Powders

aiRFlex®

1" to 24"/25mm-600mm ID, Full Port
Industry Standard ASME/ANSI
B-16.10, DIN and ISO Face-to-Face
INTERCHANGEABLE with most
Ball, Plug, Gate, Globe Valves



Operating Benefits

- No moving parts; only one wear-resistant elastomer component
- Self-cleaning; will not jam or seize
- Seals on solids; gentle closing
- Superior price performance, as no actuator or costly maintenance required
- Up to 60 psi/4 bar shut-off
- Non-stretch folds significantly extend tube life over conventional design
- Full-port opening
- In-line tube change
- Actuation by air, hydraulic

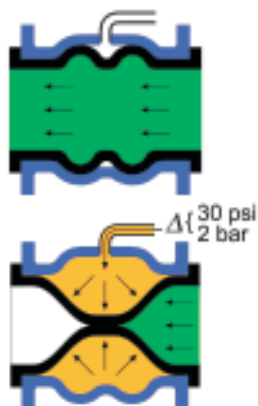

The patented tube folds minimize stretching when air is introduced between the valve body and the tube to close the valve. This prevents the most frequent cause of failure of conventional air-actuated pinch valves.

Elastomers: Natural rubber, pure gum rubber, Butyl, Buna-N, EPDM, Hypalon®, Neoprene, Viton®, HNBR, food grades

Viton® and Hypalon® are registered trademarks of DuPont Dow Elastomers

Valve Body:

- Cast iron ■ Aluminum
- Stainless steel and titanium available on request

Actuation & Control:

- On/Off solenoid valve/filter/regulator
- Modulating 4-20 mA proportional pressure controller
- Manual air switch



Elastomer tube folds flex, not stretch, during valve closure

RF Technologies, Inc.
9017 Mendenhall Court
Columbia, MD 21045 USA
Tel: 410-309-1029 • Fax: 410-309-1033
email: write.to.us@rfvalve.com
• www.rfvalve.com

RF TEK Oy
Tullitie 9
53500 Lappeenranta, Finland
Phone: 358-5-415-0382 • Fax: 358-5-415-0342
e-mail: rfvalves@rftek.fi • www.rfvalve.com

aiRFlex®

Materials of Construction

Item	Description	Material
1	Hex Bolt	AISI 304
2	Upper Valve Body	Cast Iron or Aluminum
3	Elastomer Tube	See selection
4	Joint Sealant Tape	PTFE
5	Lower Valve Body	Cast Iron or Aluminum
6	Lock Washer	AISI 304
7	Hex Nut	AISI 304

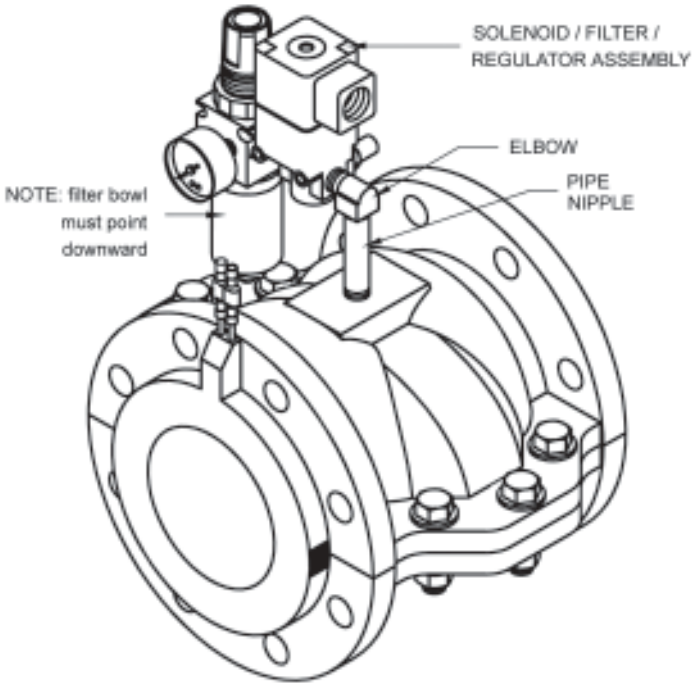
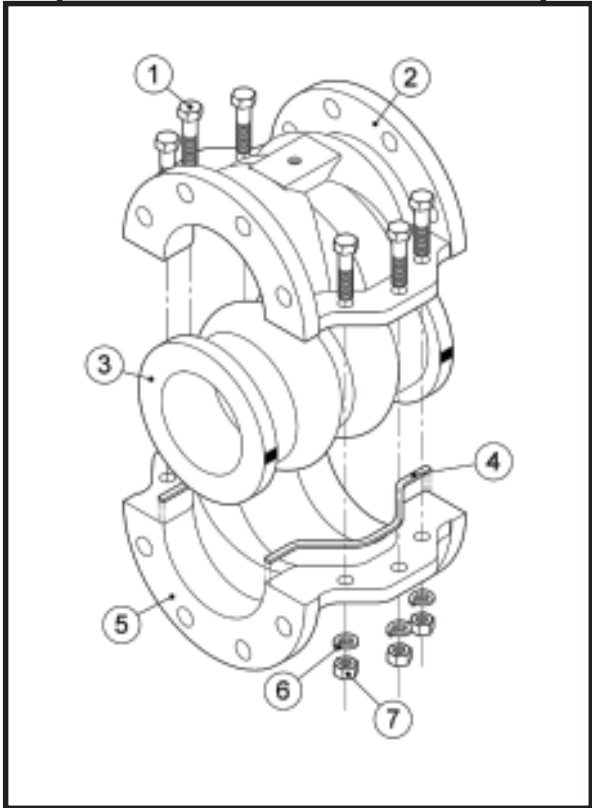

RF Technologies, Inc.
 9017 Mendenhall Court
 Columbia, MD 21045 USA
 Tel: 410-309-1029 • Fax: 410-309-1033
 email: write.to.us@rfvalve.com
 • www.rfvalve.com



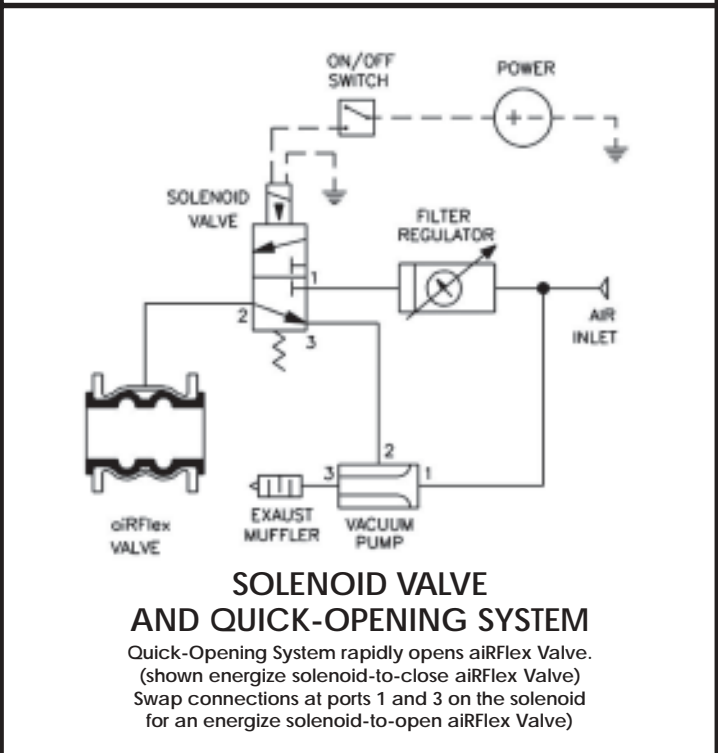
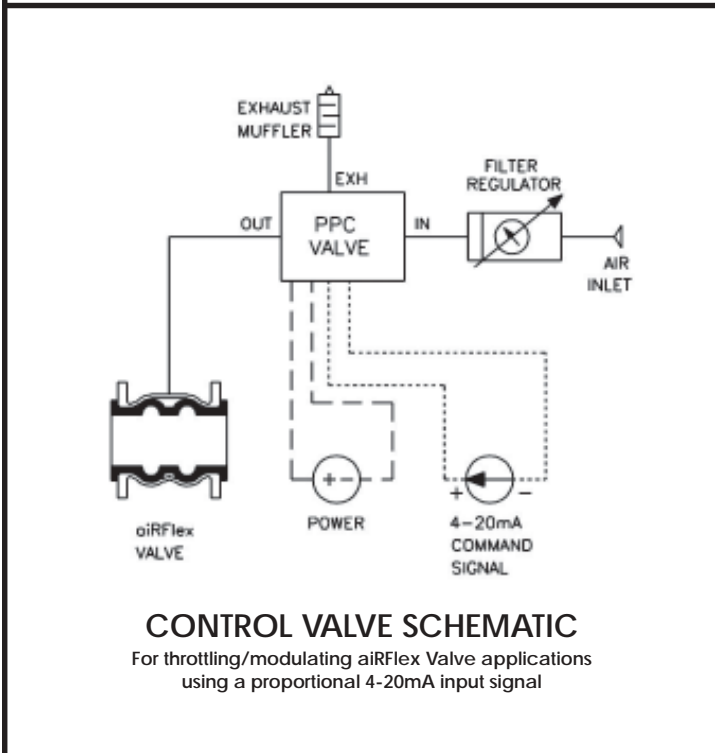
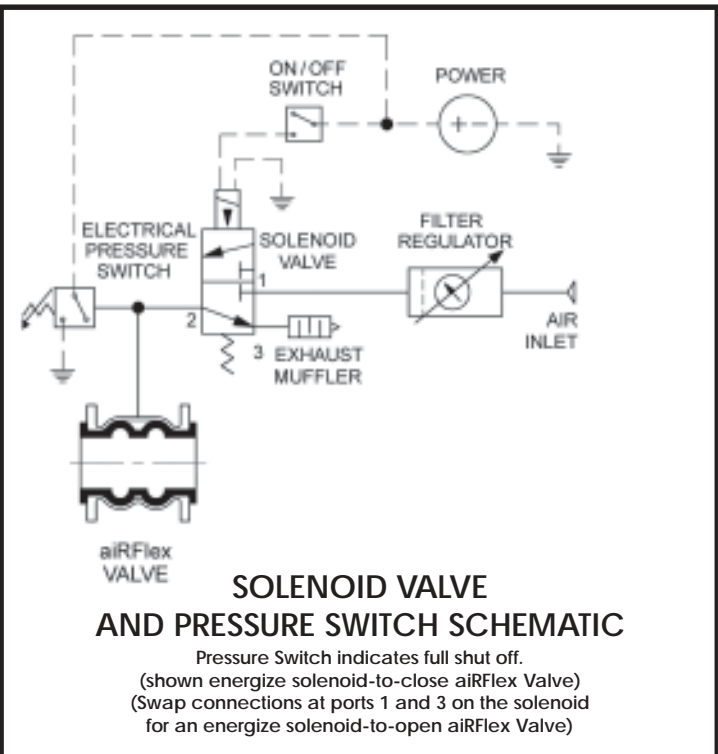
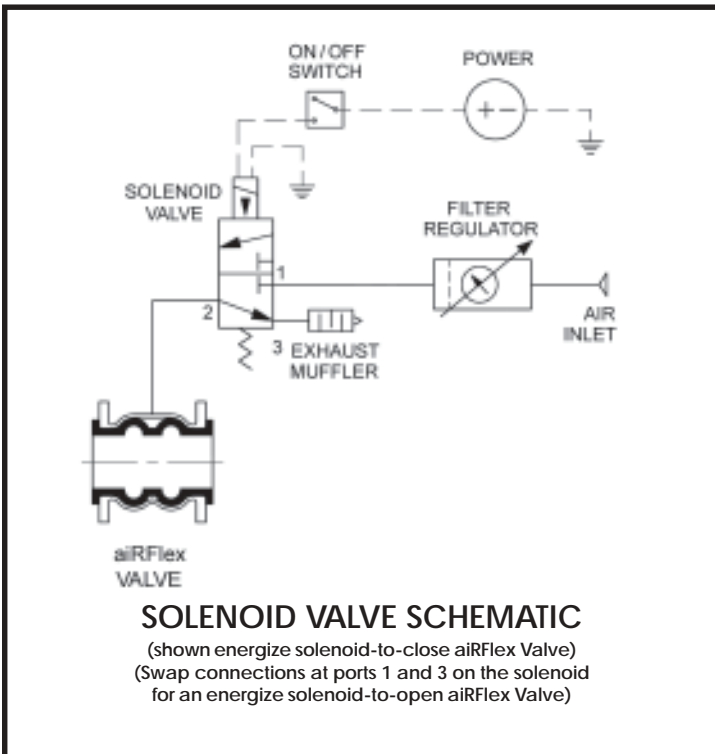

RF TEK Oy
 Tullitie 9
 53500 Lappeenranta, Finland
 Phone: 358-5-415-0382 • Fax: 358-5-415-0342
 e-mail: rfvalves@rftek.fi • www.rfvalve.com



VISIT RF TECHNOLOGIES, INC., ON THE WEB AT WWW.RFVALVE.COM

ACCESSORIES:

- Solenoid valve and filter/regulator
- 4-20 mA proportional modulating control
- Fail-close operation



- Optional SMART Valve™ Wear Sensor System
- Fail-safe supply-air shut-off
- Quick-opening system
- Pressure switches (open/close signal)



Competitive Advantages:

- ASME B16.1 face-to-face
- Non-stretch elastomer tube
- Change tube in line
- s/s fasteners
- Interior/exterior powder coat
- Flange bolt holes unthreaded



aiRFlex



Table dimensions are for ASME/ANSI
(1) Height given is without accessories

ID		F-F		Width		Height ⁽¹⁾		Cast Iron		Aluminum	
in.	mm.	in.	mm.	in.	mm.	in.	mm.	lbs.	kg.	lbs.	kg.
1	25	5	127	5	127	4.2	107	6	2.7	3.5	1.6
1.5	40	6.5	165	5.9	150	5	127	11	5	5	2.3
2	50	7	178	8.1	206	6.5	165	17	7.7	7	3.2
2.5	65	7.5	190	7.6	194	7	178	22	10	11	5
3	80	8	203	10.1	257	7.9	201	27	12.2	14	6.3
4	100	9	229	11.6	295	9	228	37	16.8	17	7.7
5	125	10	254	12.3	312	10	254	52	23.6	24	11
6	150	10.5	267	15.2	386	11.2	284	66	29.9	43	19.5
8	200	18	457	18.3	465	13.4	340	152	68.9	77	34.9
10	250	21	533	24.3	617	16	406	-	-	155	70.3
12	300	24	610	28.2	716	19	483	-	-	205	93
14	350	27	686	27.9	709	26.8	681	-	-	284	128.8

APPLICATIONS

- **Mining:** metal and mineral concentrates, tailings, lime and chemical addition, water, acids
- **Industrial Minerals:** titanium dioxide, carbonates, iron oxide, pigments, catalyst, kaolin, talc, potash, carbon, ceramics, glass, concrete, fiberglass, magnesium, silica
- **Chemicals:** most abrasive and corrosive liquids or slurries
- **Water and Wastewater:** scaling-prone liquids and chemicals, primary and secondary sludge, grit, screening, flocculation
- **Pneumatic Conveying:** grains, cement, silica sand, pellets, fiber, ash, dust
- **Food and Beverage:** sugar, cereals, fruit and vegetable processing, juices, syrup, mash, waste handling
- **Power Generation:** fly ash, scrubber slurries, cooling and reactor water, neutralization
- **Steel:** quench water, pickling, chemical addition, process water, foundry sand, lime
- **Pulp and Paper:** pulp, liquors, lime mud, coatings, rejects, recycle, dregs, corn starch, sand traps, junk traps

RF Technologies, Inc.
9017 Mendenhall Court
Columbia, MD 21045 USA
Tel: 410-309-1029 • Fax: 410-309-1033
email: write.to.us@rfvalve.com
• www.rfvalve.com



RF TEK Oy
Tullitie 9
53500 Lappeenranta, Finland
Phone: 358-5-415-0382 • Fax: 358-5-415-0342
e-mail: rfvalves@rftek.fi • www.rfvalve.com